

**3.2A 550k/1.1MHz Synchronous PWM/PSM****Step-Down Converter with High Light-load Efficiency****■ FEATURES**

- 2.5V to 6V Input Voltage Range
- Adjustable Output Voltage from 0.8V to  $V_{in}$
- 3.2A Guaranteed Output Current
- 88% Efficiency at Heavy Load  
( $V_{in}=5V$ ,  $V_{out}=3.3V$ ,  $I_{out}=3.2A$ )
- 95% Efficiency at Moderate Load  
( $V_{in}=5V$ ,  $V_{out}=3.3V$ ,  $I_{out}=1.5A$ )
- 91% Efficiency at Light Load  
( $V_{in}=5V$ ,  $V_{out}=3.3V$ ,  $I_{out}=50mA$ )
- Low  $R_{DS(ON)}$  Internal Switches: 110m $\Omega$
- No Schottky Diode Required
- 100% Duty Cycle in Low Dropout Operation
- Fixed 550k/1.1MHz Operating Frequency
- Optional Soft-Start Internal Fixed 1ms Soft-Start (in SOP-8)

**■ DESCRIPTION**

The AIC2363 is a low-noise, pulse-width-modulated (PWM), DC-DC step-down converter. The device features an internal synchronous rectifier for high efficiency; it requires no external Schottky diode. The AIC2363 is ideally suited for Li-Ion battery applications. Automatic PWM/PSM mode extends battery life and enhance efficiency by switching to a pulse-skipping-modulated mode during light load. Shutdown mode places the device in standby, reducing supply current to under 2 $\mu$ A.

Other features of the AIC2363 include high efficiency for all load range, low dropout voltage, short circuit protection, and over temperature protection.

**■ APPLICATIONS**

- LCD TV
- Portable Products
- Wireless and DSL Modems
- Solid-State Drives
- Battery-Operated Devices (1 Li-Ion or 3 NiMH/ NiCd)

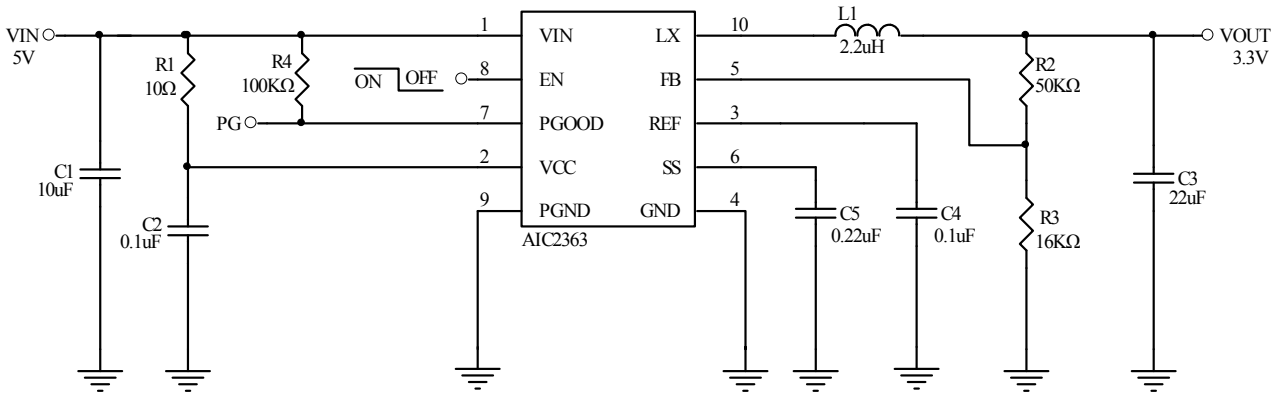
**APPLICATIONS CIRCUIT**


Fig. 1 Typical Application Circuit for DFN-10 Package

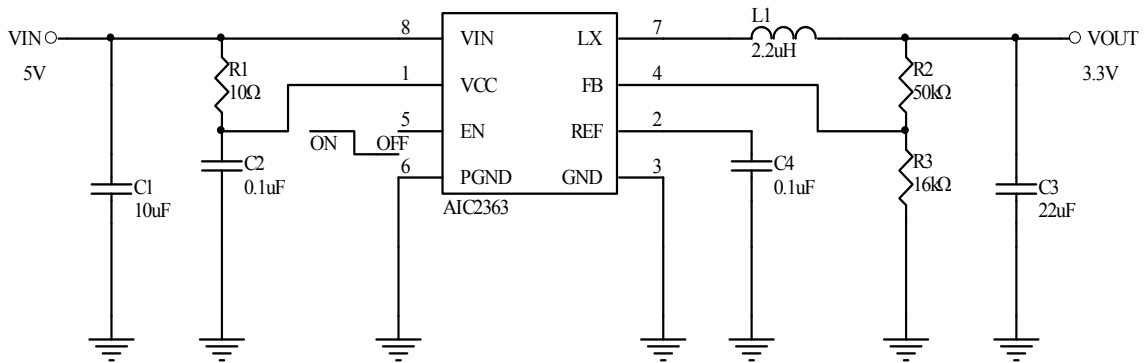
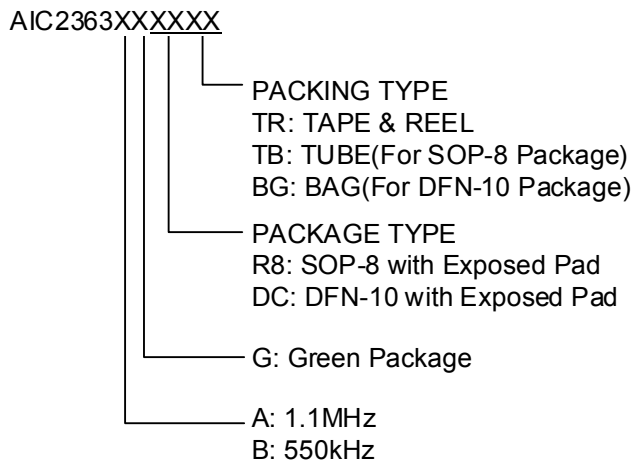
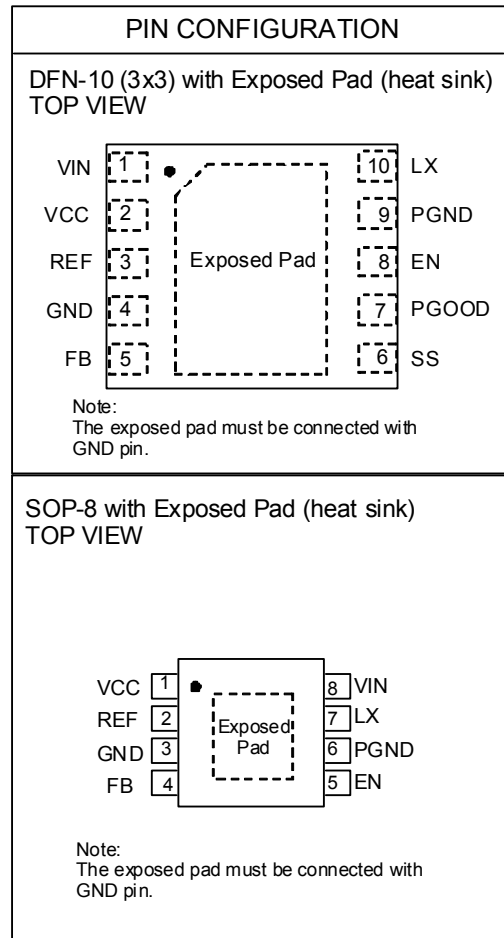


Fig. 2 Typical Application Circuit for SOP-8 Package

**■ PIN CONFIGURATION**



Example: AIC2363AGDCTR  
 → Fixed 1.1MHz Operating Frequency in Green DFN-10 with Exposed Pad Package and Tape & Reel Packing Type



**■ ABSOLUTE MAXIMUM RATINGS**

Supply Input Voltage, VCC, VIN .....	-0.3V to 6.5V
LX Pin Switch Voltage .....	-0.3V to (VIN + 0.3V)
Other I/O Pin Voltage .....	-0.3V to (VCC + 0.3V)
PGND to GND .....	+/-0.3 V
Operating Ambient Temperature Range T <sub>A</sub> .....	-40°C to 85°C
Operating Maximum Junction Temperature T <sub>J</sub> .....	150°C
Storage Temperature Range T <sub>STG</sub> .....	-65°C to 150°C
Lead Temperature (Soldering 10 Sec.).....	260°C
Thermal Resistance Junction to Case      SOP-8 (Exposed Pad) * .....	15°C/W
Thermal Resistance Junction to Case      DFN 10L (Exposed Pad)* .....	20°C/W
Thermal Resistance Junction to Ambient    SOP-8 (Exposed Pad)*.....	60°C/W
Thermal Resistance Junction to Ambient    DFN 10L (Exposed Pad)* .....	50°C/W
Latch-Up .....	200mA
HBM (Human Body Mode).....	4KV
(Assume no Ambient Airflow)	

**Absolute Maximum Ratings are those values beyond which the life of a device may be impaired.**

\* The package is placed on a two layers PCB with 2 ounces copper and 2 square inch, connected by 8 vias.

**ELECTRICAL CHARACTERISTICS**
**(T<sub>A</sub>=25°C, V<sub>IN</sub>=3.3V, unless otherwise specified.) (Note1)**

PARAMETER	CONDITIONS	SYMBOL	MIN	TYP	MAX	UNITS
Input Voltage Range		V <sub>IN</sub>	2.5		6	V
Under Voltage Lockout Threshold	V <sub>CC</sub> Rising	V <sub>UVLO(R)</sub>		2.3		V
	V <sub>CC</sub> Falling	V <sub>UVLO(F)</sub>		2.1		V
Output Adjustment Range		V <sub>OUT</sub>	0.8		V <sub>IN</sub>	V
Shutdown Current	V <sub>EN</sub> = 0V	I <sub>SD</sub>		1	2	μA
Quiescent Current (SOP-8 Package)	I <sub>OUT</sub> = 0A, V <sub>FB</sub> = 1V No Switching	I <sub>Q</sub>		200	380	μA
Quiescent Current (DFN-10 Package)	I <sub>OUT</sub> = 0A, V <sub>FB</sub> = 1V No Switching	I <sub>Q</sub>		300	480	μA
Standby Current	I <sub>OUT</sub> = 0A, Switching	I <sub>SB</sub>		600	900	μA
Feedback Reference Voltage		V <sub>REF</sub>	0.784	0.8	0.816	V
VO <sub>UT</sub> Line Regulation	V <sub>IN</sub> = 2.5V to 5.5V	ΔV <sub>OUT</sub>	-2		2	%
FB Leakage Current		I <sub>FB</sub>		0.1	0.2	μA
EN Supply Current		I <sub>EN</sub>		3.5		μA
En Logic High			1.5		V <sub>CC</sub>	V
EN Logic Low			0		0.5	V
P-Channel On-Resistance	I <sub>LX</sub> = 0.2A	R <sub>D<sub>SH</sub>(ON)</sub>		110		mΩ
N-Channel On-Resistance	I <sub>LX</sub> = 0.2A	R <sub>D<sub>SL</sub>(ON)</sub>		80		mΩ
Switch Leakage Current	V <sub>EN</sub> = 0V, V <sub>IN</sub> = 5.5V			0.1	1	μA
Peak Inductor Current		I <sub>PK</sub>	4	5		A
Oscillator Frequency (A Version)		f <sub>OSCA</sub>	920	1100	1280	kHz
Oscillator Frequency (B Version)		f <sub>OSCB</sub>	468	550	632	kHz
Maximum Duty Cycle		D <sub>MAX</sub>	100			%
Thermal Shutdown Trip Point		T <sub>OTP</sub>		150		°C
Thermal Shutdown Hysteresis		T <sub>OTP_HYS</sub>		25		°C
PGood Leakage Current	PGOOD=5V	I <sub>PGOOD</sub>			1	μA
PGood Voltage Low	I <sub>PGOOD</sub> =1mA	V <sub>PGL</sub>		0.2		V
PGood High Window	With respect to nominal output, T <sub>A</sub> =T <sub>J</sub> =25°C		±5	±10	±15	%
PGood Delay Time	V <sub>out</sub> Rising or V <sub>out</sub> Fal- ling			1024		clks
Soft-Start Charge Current		I <sub>SS</sub>		4		μA

Note 1: Specifications are production tested at T<sub>A</sub>=25°C. Specifications over the -40°C to 85°C operating temperature range are assured by design, characterization and correlation with Statistical Quality Controls (SQC).

**TYPICAL PERFORMANCE CHARACTERISTICS**

(C1=10 $\mu$ F,C3=22 $\mu$ F,L1=2.2 $\mu$ H,TA=25 $^{\circ}$ C, unless otherwise noted)

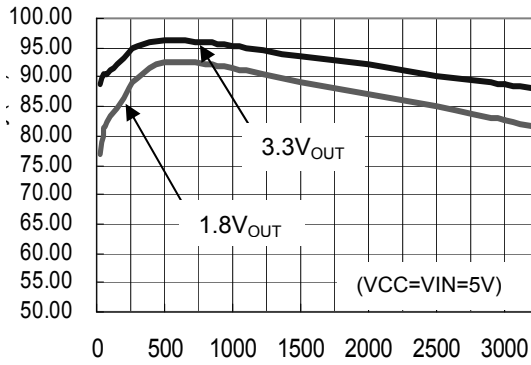


Fig. 3 Efficiency vs load Current

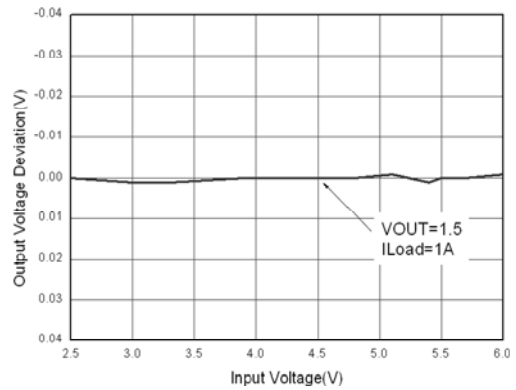


Fig. 4 Output Voltage Deviation vs Input Voltage

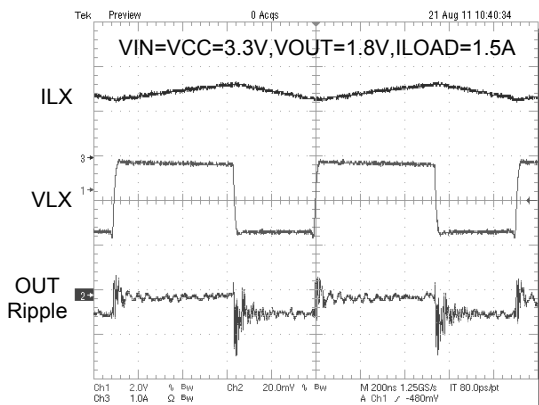


Fig. 5 Switching Waveform

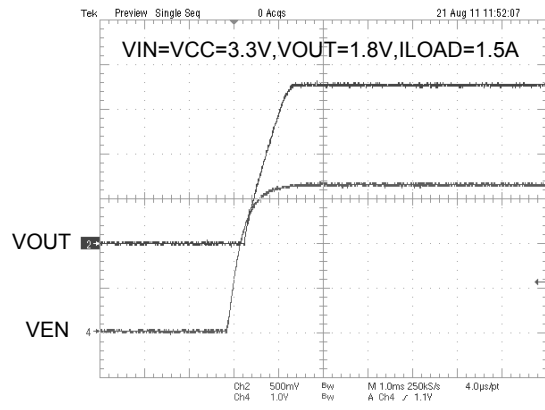


Fig. 6 Soft Start Waveform

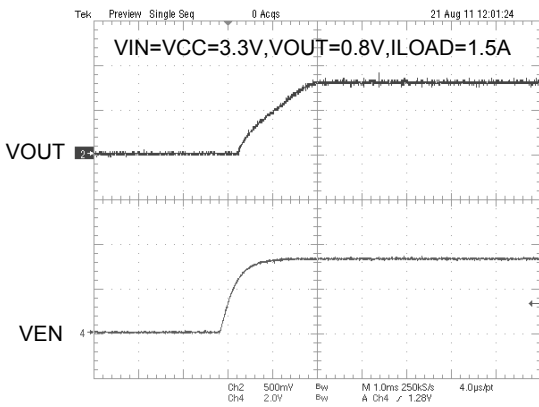


Fig. 7 Soft Start Waveform

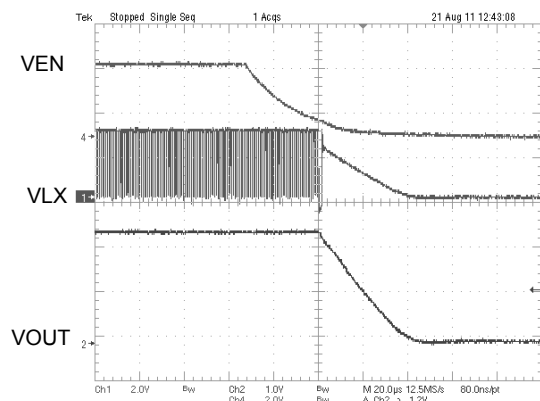


Fig. 8 Shutdown Waveform

**TYPICAL PERFORMANCE CHARACTERISTICS (Continued)**

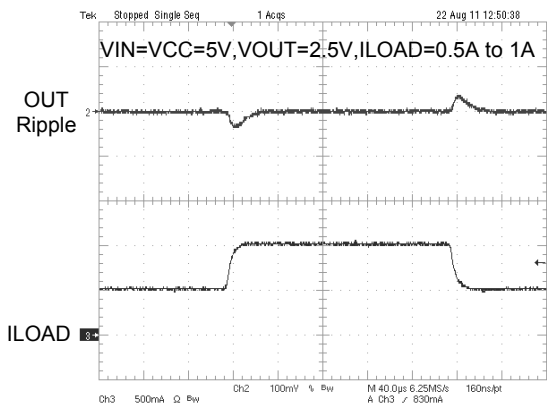


Fig. 9 Load Transient Response

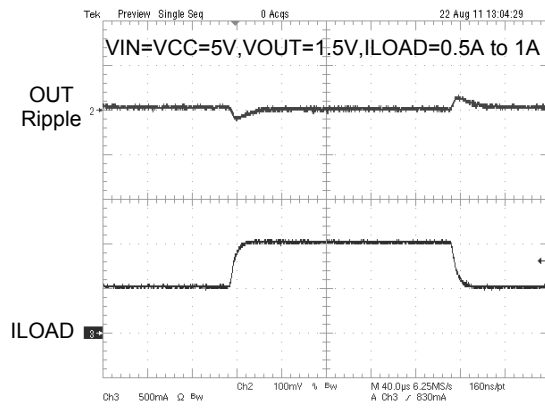


Fig. 10 Load Transient Response

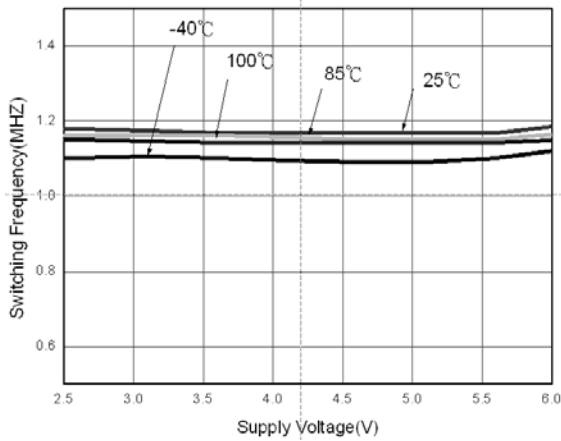


Fig. 11 Switching Frequency vs Input Voltage

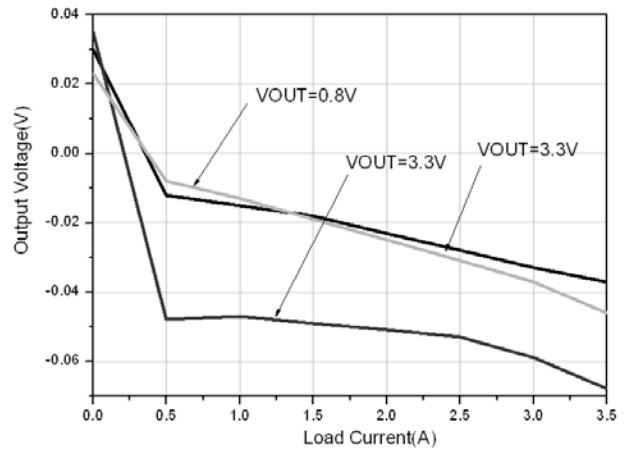
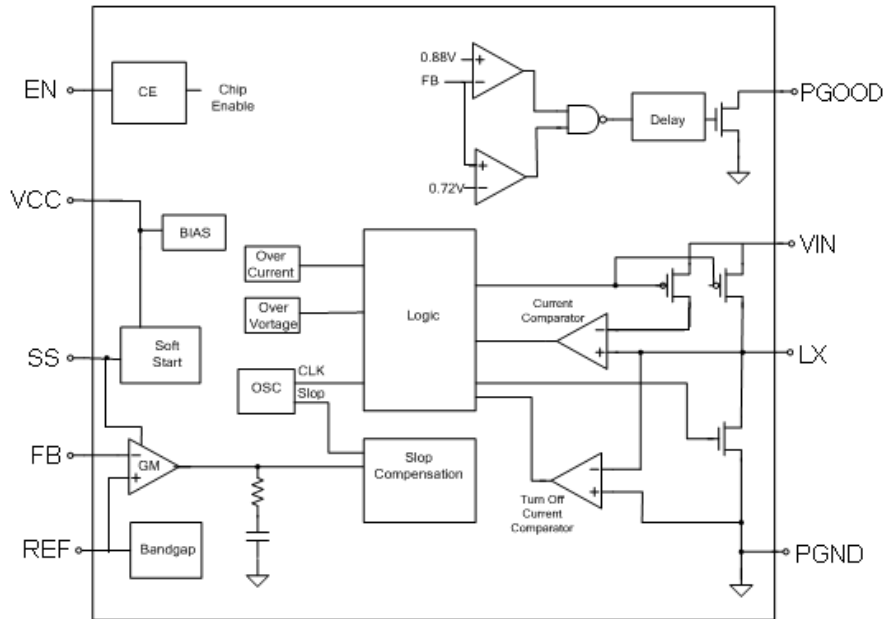


Fig. 12 Output Voltage Deviation vs Load Current

■ BLOCK DIAGRAM



Functional Block Diagram of AIC2363



**■ PIN DESCRIPTIONS**  
**(For DFN-10 PACKAGE)**

Pin No.	Pin Name	Pin Function
1	VIN	Power Input Supply. Decouple this pin to PGND with a capacitor.
2	VCC	Signal Input Supply. Decouple this pin to GND with a capacitor. Normally VCC is equal to VIN.
3	REF	Internal Reference Voltage. Decouple this pin to GND with a capacitor.
4	GND	Signal Ground. All small-signal components and compensation components should connect to this ground, which in turn connects to PGND at one point.
5	FB	Feedback Pin. This pin receives the feedback voltage from a resistive divider connect across the output.
6	SS	Soft-Start Control Input. SS Controls the soft-start period. Connect a capacitor from SS to GND to set the soft-start period.
7	PGOOD	Power good indicator. It is an open drain output. Low when the output is out of the power good high window.
8	EN	Enable Pin. Connect to logic high in normal operation. Forcing this ping to GND cause the device to be shutdown.
9	PGND	Power Ground. Connect this pin to the negative terminal of C <sub>IN</sub> and C <sub>OUT</sub> .
10	LX	Internal Power MOSFET Switches Output. Connect this pin to the inductor.

**(For SOP-8 PACKAGE)**

Pin No.	Pin Name	Pin Function
1	VCC	Signal Input Supply. Decouple this pin to GND with a capacitor. Normally VCC is equal to VIN.
2	REF	Internal Reference Voltage. Decouple this pin to GND with a capacitor.
3	GND	Signal Ground. All small-signal components and compensation components should connect to this ground, which in turn connects to PGND at one point.
4	FB	Feedback Pin. This pin receives the feedback voltage from a resistive divider connect across the output.
5	EN	Enable Pin. Connect to logic high in normal operation. Forcing this pin to GND cause the device to be shutdown.
6	PGND	Power Ground. Connect this pin to the negative terminal of C <sub>IN</sub> and C <sub>OUT</sub> .
7	LX	Internal Power MOSFET Switches Output. Connect this pin to the inductor.
8	VIN	Power Input Supply. Decouple this pin to PGND with a capacitor.

## ■ APPLICATION INFORMATION

### Operation

The AIC2363 is a low-noise step-down DC/DC converter with current-mode PWM/PSM control architecture. It features an internal synchronous rectifier, which eliminates the external Schottky diode and increases efficiency. During normal operation, the AIC2363 can regulate its output voltage through a feedback control circuit, which is composed of an error amplifier; a current comparator and several control signal generators. By comparing the feedback voltage to the reference voltage of 0.8V, the error amplifier varies its output voltage. The output voltage of the error amplifier is compared with the summing signal of current sensing signal and slope compensation signal to determine the duty cycle of internal main power switch (P-channel MOSFET). While the main power switch is turned on, the synchronous power switch (N-channel MOSFET) will be turned off through anti-short-through block. Similarly, when the main power switch is turned off, the synchronous power switch will be turned on until the inductor current starts to reverse or the beginning of the next switching cycle. In order to achieve better efficiency and prevent overcharging the output capacitor, AIC2363 will enter pulse-skipping-modulated mode (PSM) operation while working at light load conditions.

### Current Limitation

The AIC2363 provides current limit function by using an internal sensing resistor. When the main power switch turns on, current follows through the internal sensing resistor. And current amplifier senses the voltage, which crosses the resistor, and amplifies it. While the sensed voltage gets higher than reference voltage, the current limitation function is activated. While the current limitation function is activated, the duty cycle will be reduced to limit the output power to protect the internal power switches.

### Short Circuit Protection

While the output is shorted to ground, the switching frequency of AIC2363 will be reduced to one fourth of the normal switching frequency. This lower switching frequency ensures the inductor current has more time to discharge, thereby preventing inductor current runaway. The switching frequency will automatically return to its designed value while short circuit condition is released.

### Shutdown

By connecting the EN pin to GND, the AIC2363 can be shut down to reduce the supply current to 2 $\mu$ A (typical). At this operation mode, the output voltage of step-down converter is equal to 0V.

### 100% Duty Cycle Operation

When the input voltage approaches the output voltage, the AIC2363 smoothly transits to 100% duty cycle operation. This allows AIC2363 to regulate the output voltage until AIC2363 completely enters 100% duty cycle operation. In 100% duty cycle mode, the output voltage is equal to the input voltage minus the voltage, which is the drop across the main power switch.

The AIC2363 achieves 100% duty cycle operation by extending the turn-on time of the main power switch. If the summing signal of current sensing signal and slope compensation signal does not reach the output voltage level of the error amplifier at the end of 90% switching period, the main power switch is continuously turned on and the oscillator remains off until the summing signal of current sensing signal and slope compensation signal reaches the output voltage level of the error amplifier. After the summing signal of current sensing signal and slope compensation signal reaches the output voltage level of the error amplifier, the main power switch is turned off and the synchronous power switch is turned on for a constant off time. At the end of the constant off time, the next

switching cycle is begun. While the input voltage approaches the output voltage, the switching frequency decreases gradually to smoothly transit to 100% duty cycle operation.

If input voltage is very close to output voltage, the switching mode goes from pure PWM mode to 100% duty cycle operation. During this transient state mentioned above, large output ripple voltage may appear on output terminal.

## Components Selection

### Inductor

The inductor selection depends on the current ripple of inductor, the input voltage and the output voltage.

$$L \geq \frac{V_{OUT}}{f_{OSC} \cdot \Delta I_L} \left( 1 - \frac{V_{OUT}}{V_{IN}} \right)$$

Accepting a large current ripple of inductor allows the use of a smaller inductance. However, higher current ripple of inductor can cause higher output ripple voltage and large core loss. By setting an acceptable current ripple of inductor, a suitable inductance can be obtained from above equation.

In addition, it is important to ensure the inductor saturation current exceeds the peak value of inductor current in application to prevent core saturation. The peak value of inductor current can be calculated according to the following equation.

$$I_{PEAK} = I_{OUT(max)} + \frac{V_{OUT}}{2 \times f_{OSC} \cdot L} \left( 1 - \frac{V_{OUT}}{V_{IN}} \right)$$

### Input Capacitor and Output Capacitor

To prevent the high input voltage ripple and noise resulted from high frequency switching, the use of low ESR ceramic capacitor for the maximum RMS current is recommended. The approximated RMS current of the input capacitor can be calculated according to the following equation.

$$I_{CINRMS} \approx \sqrt{I_{OUT(MAX)}^2 \times \frac{V_{OUT}(V_{IN} - V_{OUT})}{V_{IN}^2} + \frac{\Delta I_L^2}{12}}$$

The selection of output capacitor depends on the required output voltage ripple. The output voltage ripple can be expressed as:

$$\Delta V_{OUT} = \frac{\Delta I_L}{8 \times f_{OSC} \cdot C_{OUT}} + ESR \cdot \Delta I_L$$

For lower output voltage ripple, the use of low ESR ceramic capacitor is recommended. The tantalum capacitor can also be used well, but its ERS is larger than that of ceramic capacitor.

When choosing the input and output ceramic capacitors, X5R and X7R types are recommended because they retain their capacitance over wider ranges of voltage and temperature than other types.

### Output Voltage Programming

By connecting a resistive divider  $R_2$  and  $R_3$ , the output voltage of AIC2363 step-down converter can be set.  $V_{OUT}$  can be calculated as:

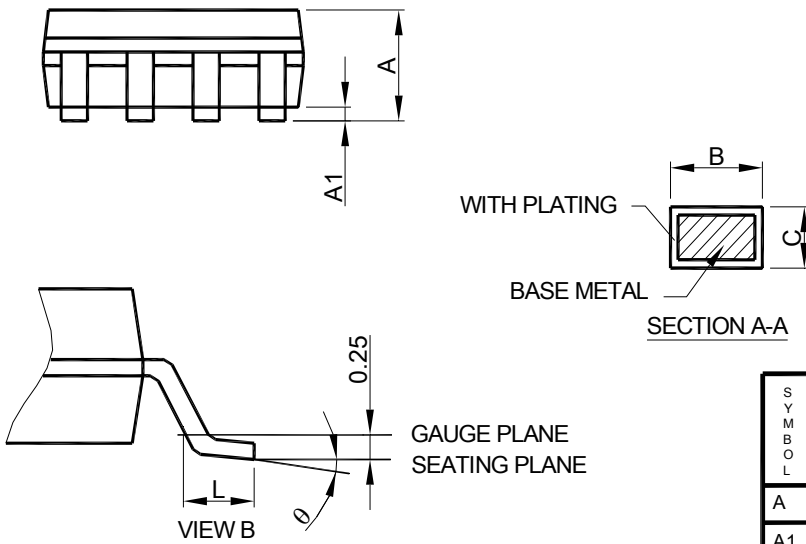
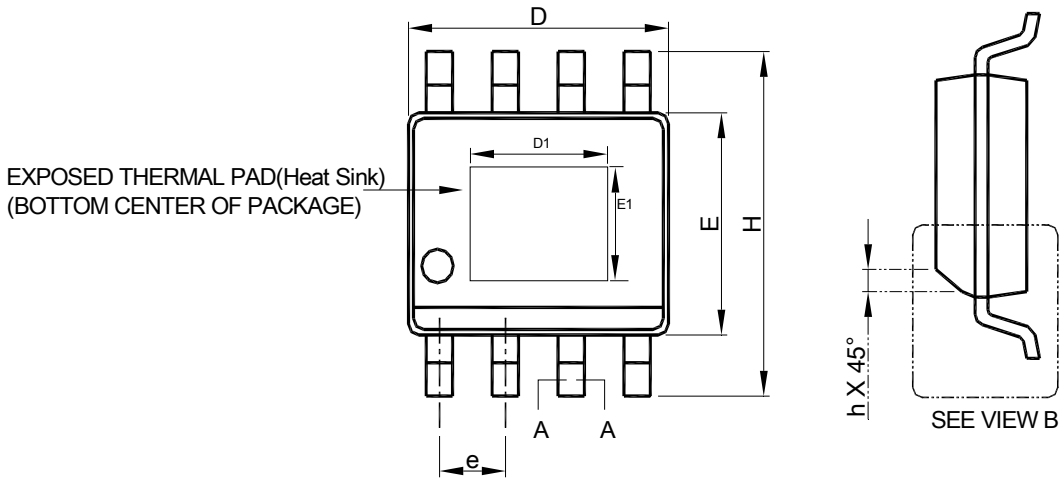
$$V_{OUT} = 0.8 \times \left( 1 + \frac{R_2}{R_3} \right)$$

The resistive divider should sit as close to VFB pin as possible.

## Layout Consideration

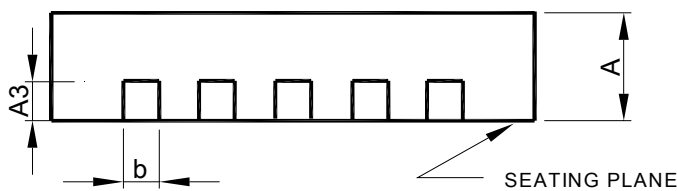
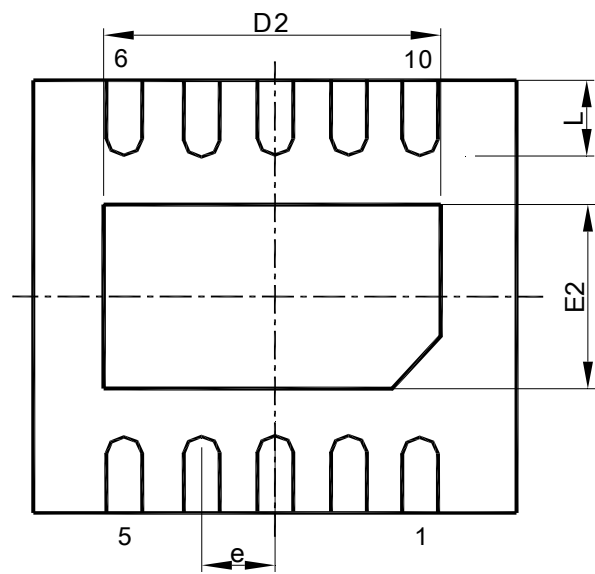
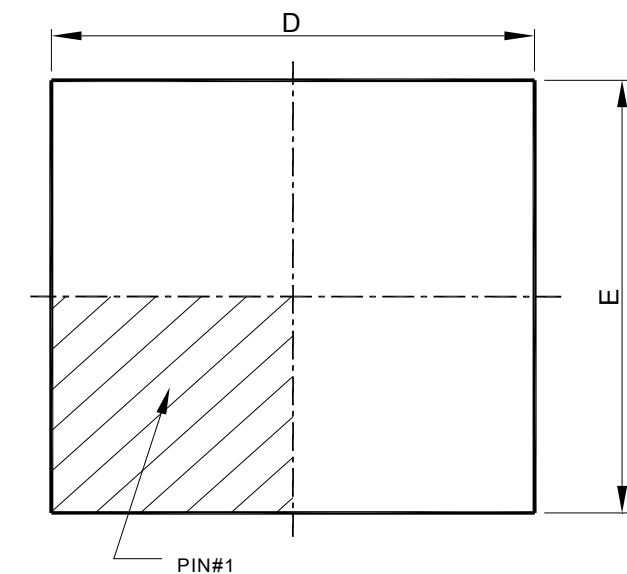
In order to ensure a proper operation of AIC2363, the following points should be managed comprehensively.

1. The input capacitor and  $V_{IN}$  should be placed as close as possible to each other to reduce the input voltage ripple and noise.
2. The output loop, which is consisted of the inductor, the internal main power switch, the internal synchronous power switch and the output capacitor, should be kept as small as possible.
3. The routes with large current should be kept short and wide.
4. Logically the large current on the converter should flow at the same direction.
5. The VFB pin should be connected to the feedback resistors directly and the route should be away from the noise sources.

**PHYSICAL DIMENSIONS (unit: mm)**
**● SOP-8 Exposed Pad (Heat Sink)**


- Note :
1. Refer to JEDEC MS-012E.
  2. Dimension "D" does not include mold flash, protrusions or gate burrs. Mold flash, protrusion or gate burrs shall not exceed 6 mil per side .
  3. Dimension "E" does not include inter-lead flash or protrusions.
  4. Controlling dimension is millimeter, converted inch dimensions are not necessarily exact.

SYMBOL	SOP-8 Exposed Pad(Heat Sink)	
	MILLIMETERS	
	MIN.	MAX.
A	1.35	1.75
A1	0.00	0.15
B	0.31	0.51
C	0.17	0.25
D	4.80	5.00
D1	1.50	3.50
E	3.80	4.00
E1	1.0	2.55
e	1.27 BSC	
H	5.80	6.20
h	0.25	0.50
L	0.40	1.27
θ	0°	8°

**DFN-10L-3X3 PACKAGE**


SYMBOL	DFN 10L-3x3x0.75-0.5mm	
	MILLIMETERS	
	MIN.	MAX.
A	0.70	0.80
A3	0.20 BSC	
b	0.18	0.30
D	2.90	3.10
D2	2.20	2.70
E	2.90	3.10
E2	1.40	1.80
e	0.5 BSC	
L	0.30	0.50

Note : 1. DIMENSION AND TOLERANCING CONFORM TO ASME Y14.5M-1994.  
 2. CONTROLLING DIMENSIONS : MILLIMETER , CONVERTED INCH DIMENSION ARE NOT NECESSARILY EXACT.

**Note:**

Information provided by AIC is believed to be accurate and reliable. However, we cannot assume responsibility for use of any circuitry other than circuitry entirely embodied in an AIC product; nor for any infringement of patents or other rights of third parties that may result from its use. We reserve the right to change the circuitry and specifications without notice.

Life Support Policy: AIC does not authorize any AIC product for use in life support devices and/or systems. Life support devices or systems are devices or systems which, (i) are intended for surgical implant into the body or (ii) support or sustain life, and whose failure to perform, when properly used in accordance with instructions for use provided in the labeling, can be reasonably expected to result in a significant injury to the user.