

FEATURES

- 2.4V to 7V Input Voltage Operation.
- Adjustable Output Voltage up to -40V.
- Low Quiescent Current at 80 μ A.
- Pulse Frequency Modulation Maintains High Efficiency (87%).
- 70KHz to 160KHz Switching Frequency.
- Power-Saving Shutdown Mode (0.7 μ A Typical).
- High Efficiency with Low Cost External PNP Bipolar Transistor.

APPLICATIONS

- Negative LCD Contrast Bias for
 1. Notebook & Palmtop Computers.
 2. Pen-Based Data System.
 3. Portable Data Collection Terminals.
 4. Personal Digital Assistants.
- Negative Voltage Supply.

DESCRIPTION

The AIC1652 is a high performance inverting DC/DC controller, designed to drive an external power switch to generate programmable negative voltages. In the particularly suitable LCD bias contrast application, efficiency of 87% can be achieved with low cost PNP bipolar transistor drivers. Output voltage can be scaled to -40V or greater by two external resistors. A pulse frequency modulation scheme is employed to maintain high efficiency conversion under wide input voltage range. Quiescent current is about 80 μ A and can be reduced to 0.7 μ A in shutdown mode. Switching frequency being around 70KHz to 160KHz range, small size switching components are ideal for battery powered portable equipments, like notebook and palmtop computers.

TYPICAL APPLICATION CIRCUIT

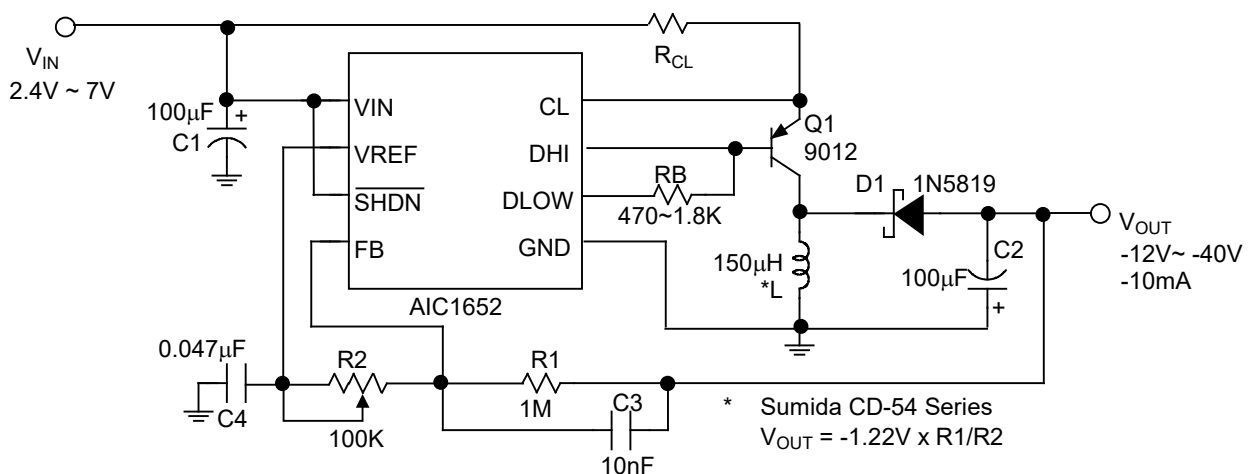

Negative LCD Contrast Bias Power Supply

ORDERING INFORMATION

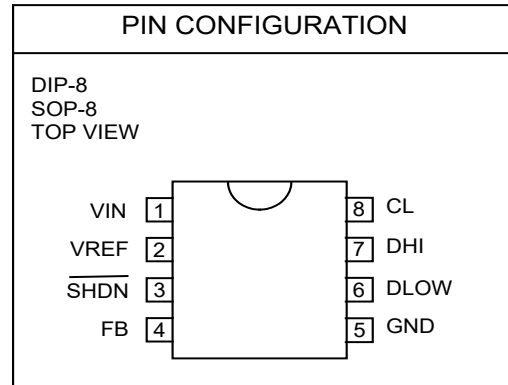
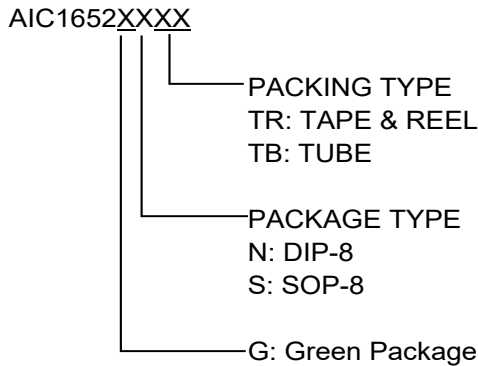

EX: AIC1652GSTR
 → in SOP-8 Green Package & Tape & Reel Packing Type
 (GN is not available in TR packing type.)

ABSOLUTE MAXIMUM RATINGS

Supply Voltage	7V
SHDN Voltage	7V
Operation Temperature Range	-40°C~85°C
Maximum Junction Temperature	125°C
Storage Temperature Range	-65°C~ 150°C
Lead Temperature (Soldering 10 Sec.)	260°C
Thermal Resistance Junction to Case	DIP-8.....	60°C/W
	SOP-8.....	40°C/W
Thermal Resistance Junction to Ambient	DIP-8.....	100°C/W
(Assume no ambient airflow, no heatsink)	SOP-8.....	160°C/W

Absolute Maximum Ratings are those values beyond which the life of a device may be impaired.

TEST CIRCUIT

Refer to Typical Application Circuit.

■ **ELECTRICAL CHARACTERISTICS** ($V_{IN}=5V$, $T_a=25^{\circ}C$, unless otherwise specified.)
(Note1)

PARAMETER	TEST CONDITIONS	MIN.	TYP.	MAX.	UNIT
Input Voltage		2.4		7	V
Switch Off Current	$V_{FB}=-50mV$		80	150	μA
V_{REF} Voltage	$I_{SOURCE} = 250\mu A$	1.16	1.22	1.28	V
V_{REF} Source Current		250			μA
DLOW "ON Resistance"			5		Ω
DHI "ON Resistance"			7		Ω
CL Threshold			70		mV
Shutdown Threshold		0.8	1.5	2.4	V
Shutdown Mode Current	$\overline{V_{SHDN}} = 0V$		0.7	2	μA

Note 1: Specifications are production tested at $T_A=25^{\circ}C$. Specifications over the $-40^{\circ}C$ to $85^{\circ}C$ operating temperature range are assured by design, characterization and correlation with Statistical Quality Controls (SQC).

TYPICAL PERFORMANCE CHARACTERISTICS

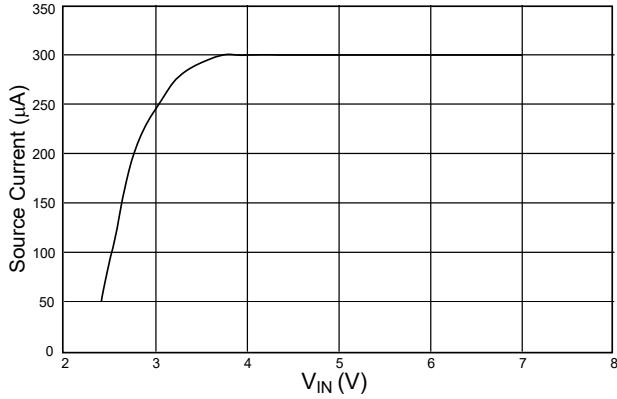

Fig. 1 V_{REF} Source Current vs. V_{IN}

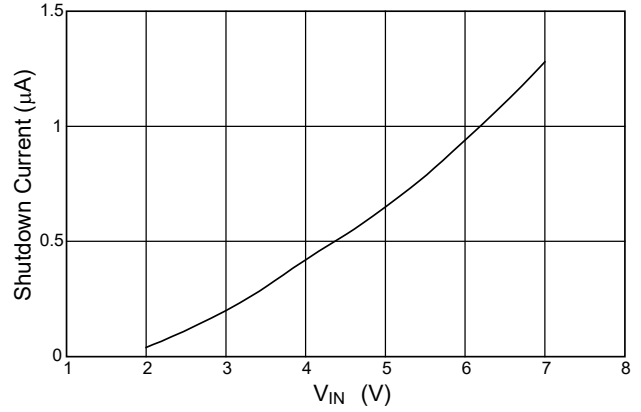

Fig. 2 Shutdown Current vs. V_{IN}

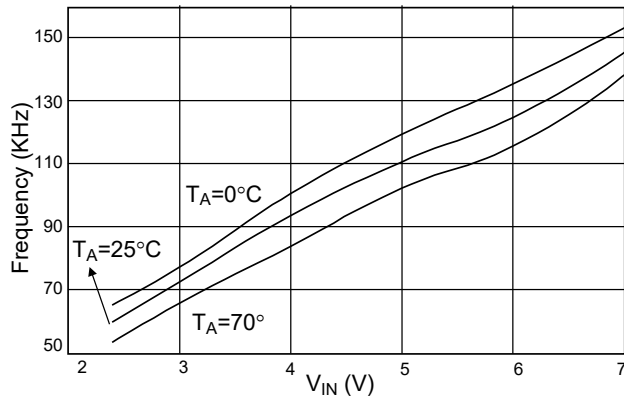

Fig. 3 Frequency vs. V_{IN} Voltage

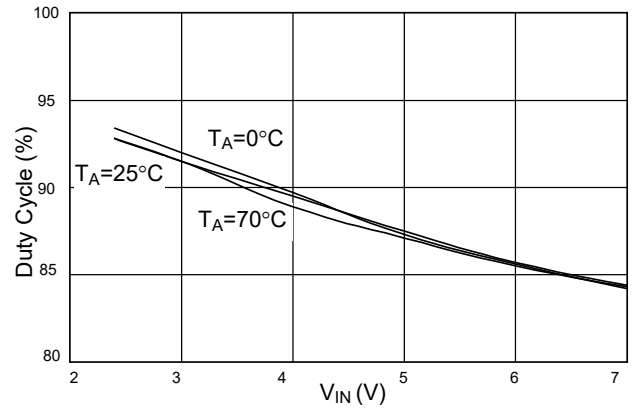

Fig. 4 Duty Cycle vs. V_{IN} Voltage

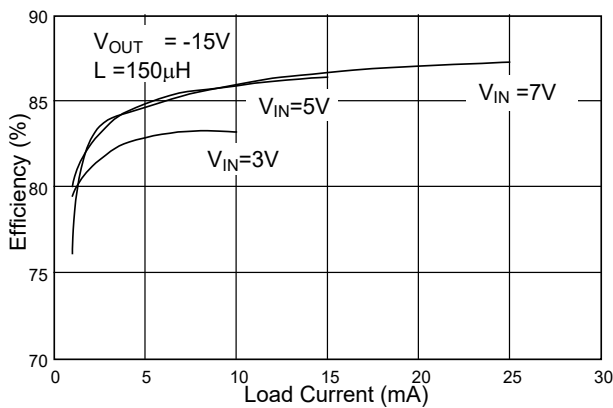

Fig. 5 Efficiency vs. Load Current

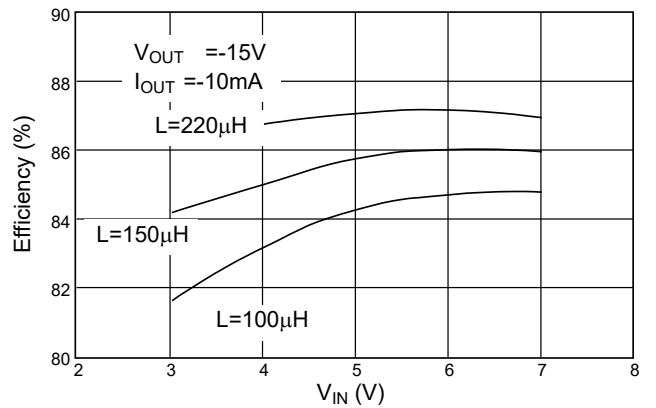

Fig. 6 Efficiency vs. V_{IN}

TYPICAL PERFORMANCE CHARACTERISTICS (Continued)

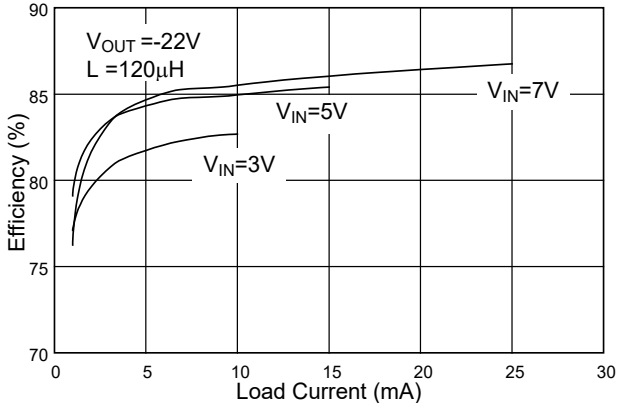

Fig. 7 Efficiency vs. Load Current

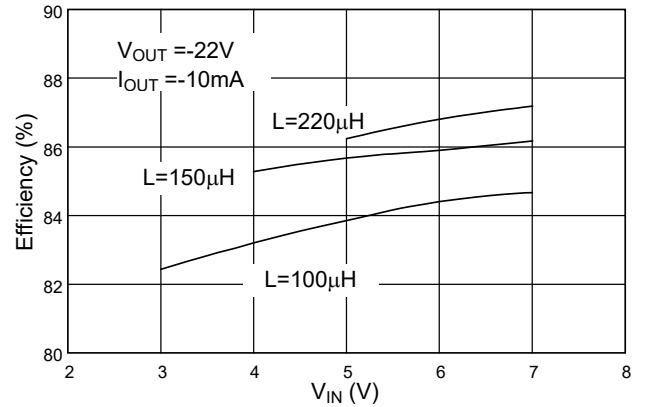

Fig. 8 Efficiency vs. V_{IN}

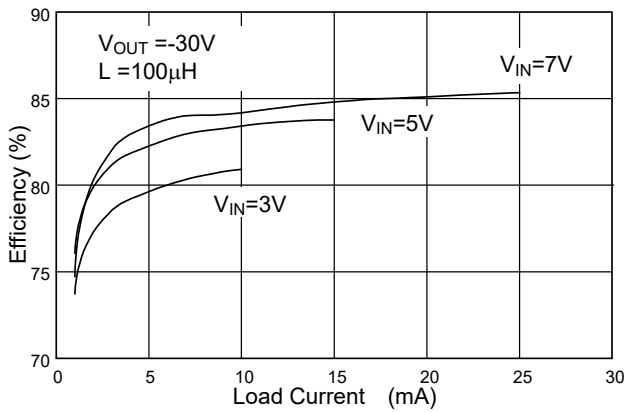

Fig. 9 Efficiency vs. Load Current

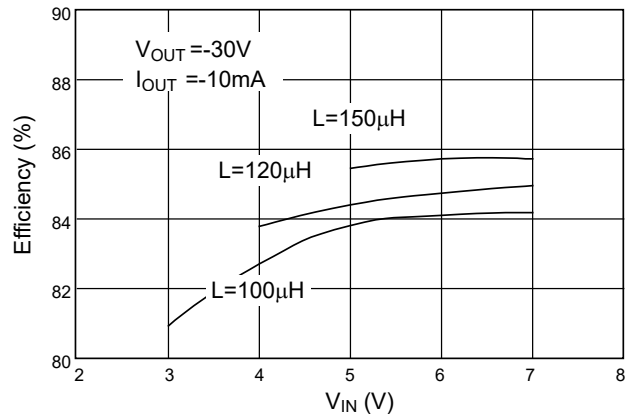
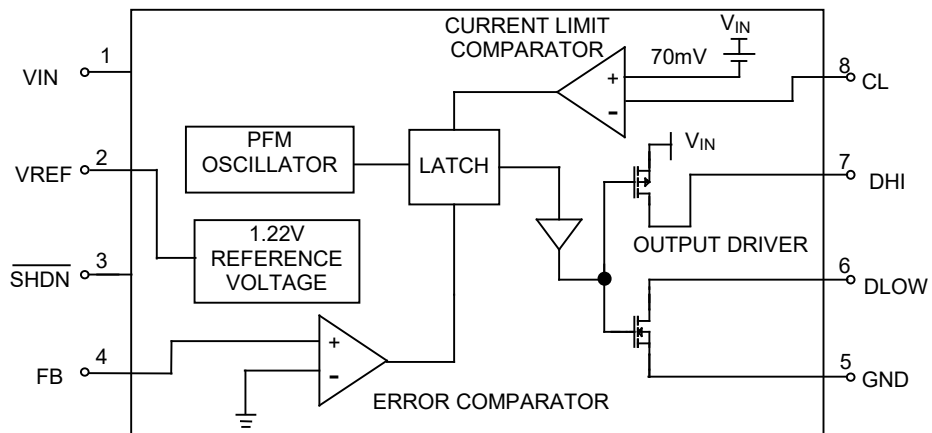

Fig. 10 Efficiency vs. V_{IN}

BLOCK DIAGRAM



■ PIN DESCRIPTIONS

- PIN 1: VIN - Input supply voltage (2.4V~7V)
- PIN 2: VREF - Reference output (1.22V). Bypass with a 0.047μF capacitor to GND. Sourcing capability is guaranteed to be greater than 250μA.
- PIN 3: $\overline{\text{SHDN}}$ - Logic input to shutdown the chip.
 >1.5V = normal operation,
 GND = shutdown
 In shutdown mode DLOW and DHI pins are at high level.
- PIN 4: FB - Feedback signal input to sense ground. Connecting a resistor R1 to VOUT and a resistor R2 to VREF pin yields the output voltage:

$$V_{OUT} = -(R1/R2) \times V_{REF}$$

- PIN 5: GND - Power ground.
- PIN 6: DLOW - Driver sinking output. When using an external PNP bipolar transistor, connect a resistor RB from this pin to DHI. RB value depends on VIN, inductor and PNP bipolar transistor. By adjusting the RB value, efficiency can be optimized.
- PIN 7: DHI - Driver sourcing output. Connect to base of the PNP bipolar transistor.
- PIN 8: CL - Current-limit input. This pin clamps the switch peak current to prevent over-current damage to the external switch.

■ APPLICATION INFORMATION

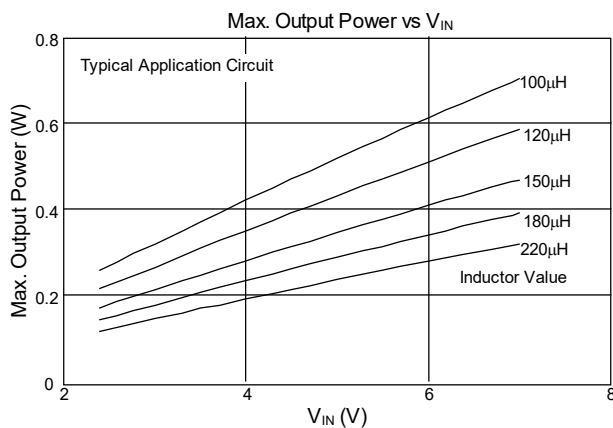

The typical application circuit generates an adjustable negative voltage for contrast bias of LCD displays. Efficiency and output power can be optimized by using appropriate inductor and switch. The following formulas provide a guideline for determining the optimal component values:

$$L = (11.1 - 0.15 \times V_{IN}) \times \frac{V_{IN}}{|I_{OUT}| \times |V_{OUT}|}$$

$$\text{PNP} : |V_{CE0}| > V_{IN} + |V_{OUT}|$$

$$|I_{C,MAX}| \geq 200 \times \frac{|I_{OUT}|}{V_{IN}}$$

$$|V_{CE}| < 0.4V \text{ at } I_C = 200 \times \frac{I_{OUT}}{V_{IN}}$$

$$\text{and } \beta = 10$$

$$R_B \cong 3 \times L \times (V_{IN} - 0.8)$$

where, VIN(V), VOUT(V), IOUT(A), L(μH), RB(Ω)

■ PHYSICAL DIMENSIONS (unit: mm)

● SOP-8

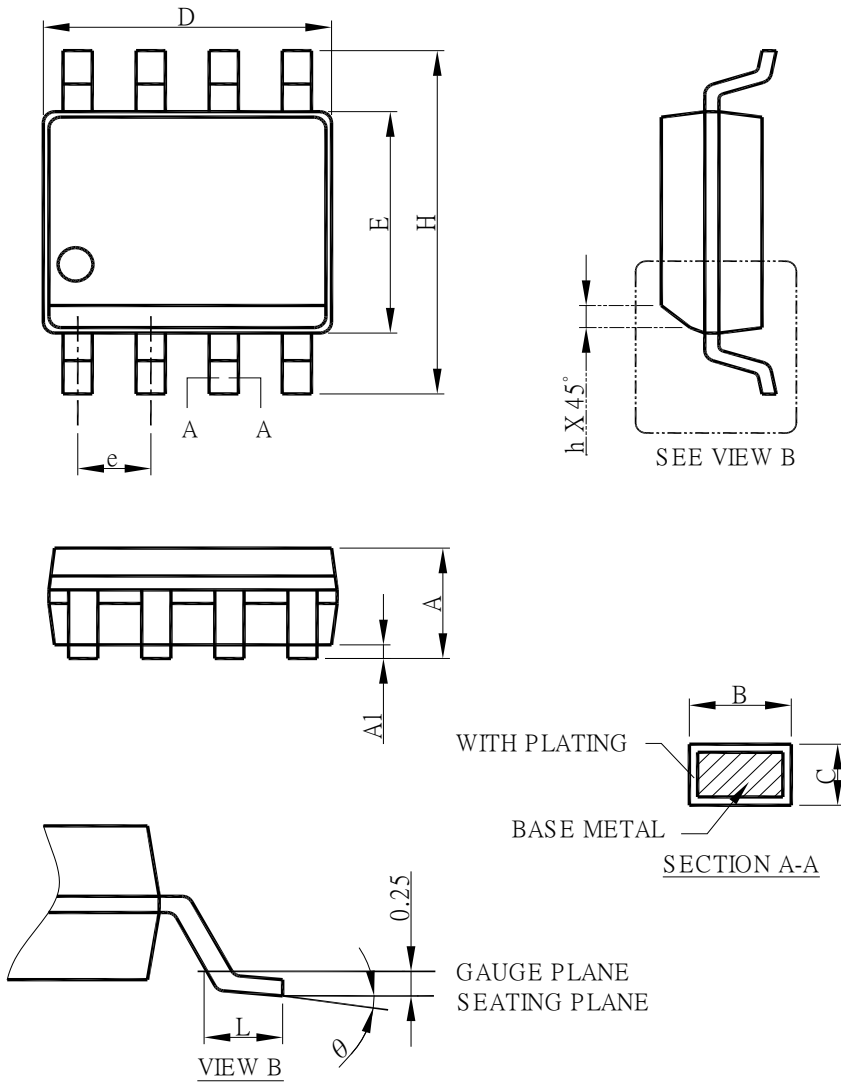

SYMBOL	SOP-8	
	MILLIMETERS	
	MIN.	MAX.
A	1.35	1.75
Al	0.10	0.25
B	0.33	0.51
C	0.19	0.25
D	4.80	5.00
E	3.80	4.00
e	1.27 BSC	
H	5.80	6.20
h	0.25	0.50
L	0.40	1.27
theta	0°	8°

- Note: 1. Refer to JEDEC MS-012AA.
 2. Dimension "D" does not include mold flash, protrusions or gate burrs. Mold flash, protrusion or gate burrs shall not exceed 6 mil per side .
 3. Dimension "E" does not include inter-lead flash or protrusions.
 4. Controlling dimension is millimeter, converted inch dimensions are not necessarily exact.

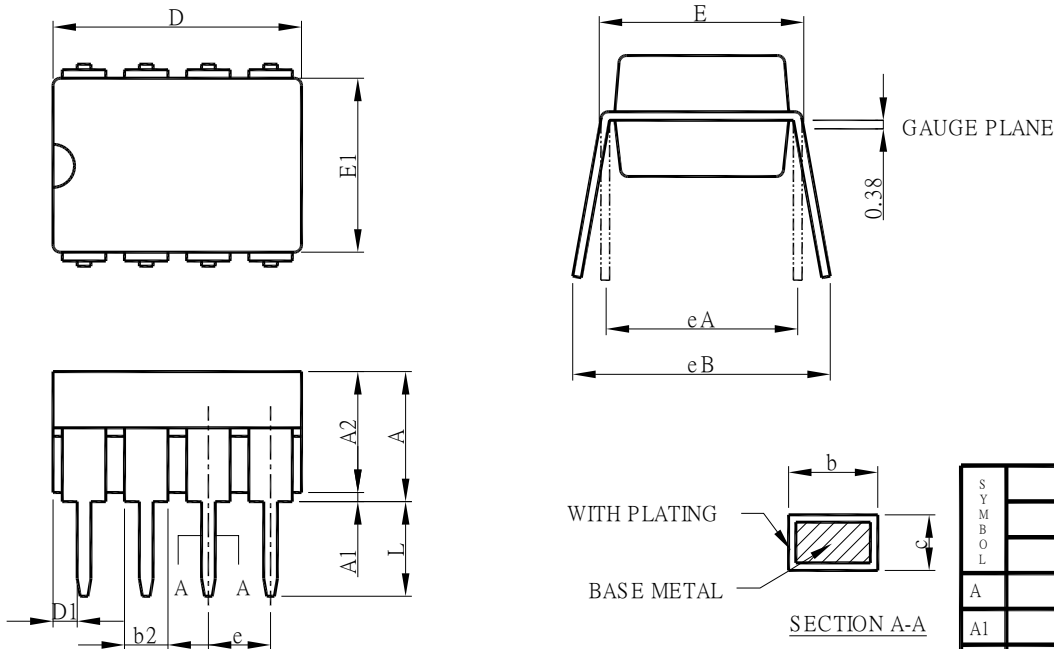
● DIP-8

SYMBOL	DIP-8	
	MILLIMETERS	
	MIN.	MAX.
A		5.33
A1	0.38	
A2	2.92	4.95
b	0.36	0.56
b2	1.14	1.78
c	0.20	0.35
D	9.01	10.16
D1	0.13	
E	7.62	8.26
E1	6.10	7.11
e	2.54 BSC	
eA	7.62 BSC	
eB		10.92
L	2.92	3.81

- Note: 1. Refer to JEDEC MS-001BA
 2. Dimension "D" does not include mold flash, protrusions or gate burrs. Mold flash, protrusion or gate burrs shall not exceed 10 mil per side .
 3. Dimension "D1" and "E1" do not include inter-lead flash or protrusions.
 4. Controlling dimension is millimeter, converted inch dimensions are not necessarily exact.

Note:

Information provided by AIC is believed to be accurate and reliable. However, we cannot assume responsibility for use of any circuitry other than circuitry entirely embodied in an AIC product; nor for any infringement of patents or other rights of third parties that may result from its use. We reserve the right to change the circuitry and specifications without notice.

Life Support Policy: AIC does not authorize any AIC product for use in life support devices and/or systems. Life support devices or systems are devices or systems which, (i) are intended for surgical implant into the body or (ii) support or sustain life, and whose failure to perform, when properly used in accordance with instructions for use provided in the labeling, can be reasonably expected to result in a significant injury to the user.