

■ FEATURES

- High Efficiency (up to 95%).
- Low Quiescent Current at 90 μ A.
- Pulse-Skipping and Pulse-Frequency Modulation.
- Inputs-Uncommitted Current Sense Comparator.
- Duty Cycle Adjustable.
- 90KHz to 280KHz Oscillator Frequency.
- Power-Saving Shutdown Mode (8 μ A Typical).
- Push-Pull Driver Output.

■ APPLICATIONS

- LCD Monitors
- Notebook Computers
- Step-Down DC/DC Controller Module.
- Constant Current Source for Battery Chargers.

■ DESCRIPTION

The AIC1578 is a high performance step-down DC/DC controller, designed to drive an external P-channel MOSFET to generate programmable output voltages. Two main schemes of Pulse-Skipping and Pulse-Frequency Modulation are employed to maintain low quiescent current and high conversion efficiency under wide ranges of input voltage and loading condition. The AIC1578 delivers 10mA to 2A of output current with 87%~93% efficiency at $V_{IN}=9V$, $V_{OUT}=5V$ condition. A current sense comparator with both inverting and non-inverting input uncommitted is included to provide the crucial function of either current limit protection or constant output current control. When the AIC1578 is used in a high-side current sensing step-down constant current source, the efficiency is typically greater than 90%. Duty cycle can be adjusted to greater than 90% by connecting a resistor from DUTY pin to V_{IN} . Quiescent current is about 90 μ A and can be reduced to 8 μ A in shutdown mode. Switching frequency being in around 90KHz to 280KHz range, small size switching components are ideal for battery powered portable equipment.

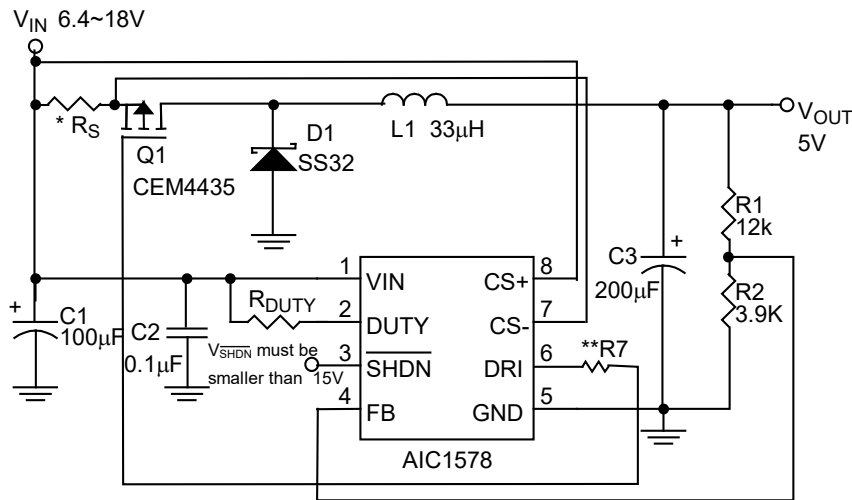
■ TYPICAL APPLICATION CIRCUIT

* R_s should not be omitted so that inrush current won't be too high.

$$I_p = I_{O,MAX} + \frac{V_{OUT}(V_{IN} - V_{OUT})}{2V_{IN} \times f_s \times L}$$

$$R_s = \frac{0.9 \times V_{TH,MIN}}{I_p} = \frac{45mV}{I_p} = \frac{0.09V_{IN}f_sL}{2V_{IN}f_sLI_{O,MAX} + V_{IN}V_{OUT} - V_{OUT}^2}$$

V_{IN} : Input voltage

V_{OUT} : Output voltage

f_s : Working frequency

L : Inductor value

$I_{O,MAX}$: Maximum Output current

$V_{TH,MIN}$: Minimum Current Limit Sense Threshold

** $V_{IN} > 15V$, $R7 = 15\Omega$

$V_{IN} \leq 15V$, $R7 = 0\Omega$

DC/DC Buck Converter
■ ORDERING INFORMATION

AIC1578XXXX

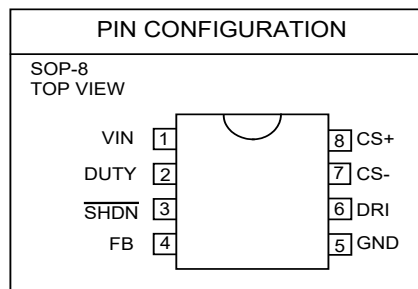
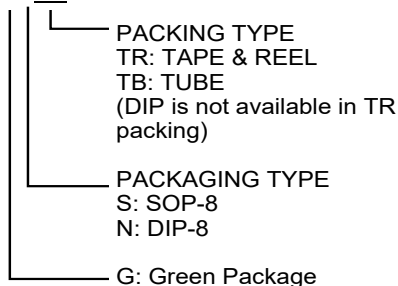

Example: AIC1578GSTR

→ in SOP-8 Green Package & Taping & Reel
Packing Type

■ ABSOLUTE MAXIMUM RATINGS

VIN Supply Voltage	18V
DUTY Voltage	18V
$\overline{\text{SHDN}}$ Voltage	15V
Operating Temperature Range	-40°C ~ 85°C
Thermal Resistance Junction to Case	DIP-8.....	60°C/W
	SOP-8.....	40°C/W
Thermal Resistance Junction to Ambient	DIP-8.....	100°C/W
(Assume no ambient airflow, no heatsink)	SOP-8.....	160°C/W
Junction Temperature Range	125°C
Storage Temperature Range	-65°C ~ 150°C
Lead Temperature (Soldering 10 Sec)	260°C

Absolute Maximum Ratings are those values beyond which the life of a device may be Impaired.

■ TEST CIRCUIT

Refer to TYPICAL APPLICATION CIRCUIT.

■ ELECTRICAL CHARACTERISTICS

($V_{IN} = 13V$, $T_A = 25^\circ C$, unless otherwise specified.) (Note 1)

PARAMETERS	CONDITIONS	MIN.	TYP.	MAX.	UNIT
Operation Voltage		4		18	V
Quiescent Current	$V_{FB} = 1.5V$		90	160	μA
Shutdown Mode Current	$\overline{V_{SHDN}} = 0V$		8	20	μA
Internal Reference Voltage		1.195	1.22	1.245	V
Driver Sinking "ON Resistance"			16		Ω
Driver Sourcing "ON Resistance"			11		Ω
Current Limit Sense Threshold	$V_{CS+} = 13V$	50	70	90	mV
Shutdown Threshold		0.6	0.9	1.2	V
\overline{SHDN} Pin Leakage Current	$V_{\overline{SHDN}} < 15V$			1	μA
Duty Cycle	$V_{DUTY} = V_{IN}$	70	75	80	%
Oscillator Frequency	$V_{DUTY} = V_{IN}$		225		KHz

Note 1 : Specifications are production tested at $T_A = 25^\circ C$. Specifications over the $-40^\circ C$ to $85^\circ C$ operating Temperature range are assured by design, characterization and correlation with Statistical Quality Controls (SQC).

TYPICAL PERFORMANCE CHARACTERISTICS

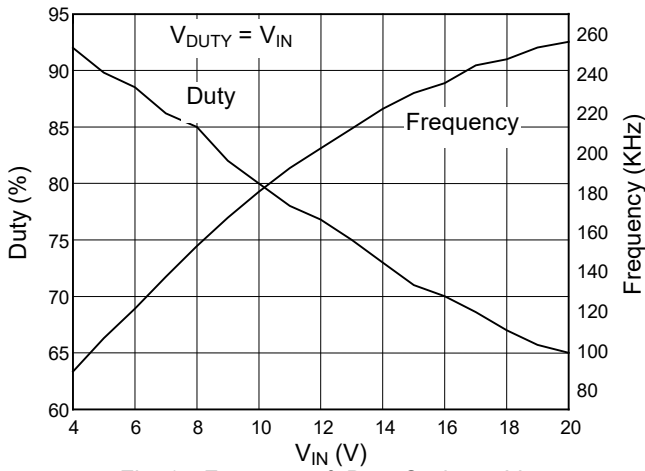

Fig. 1 Frequency & Duty Cycle vs. V_{IN}

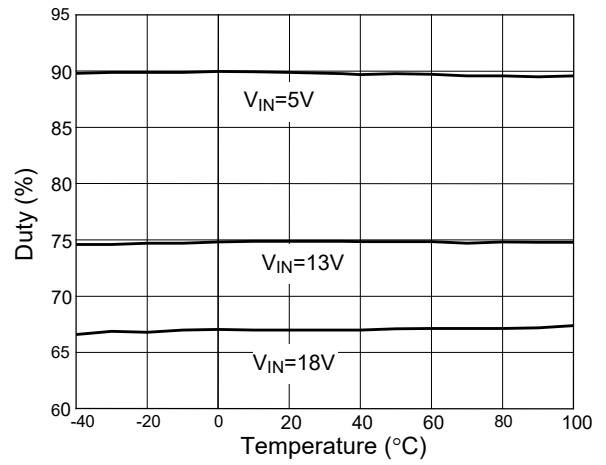

Fig. 2 Duty Cycle vs. Temperature

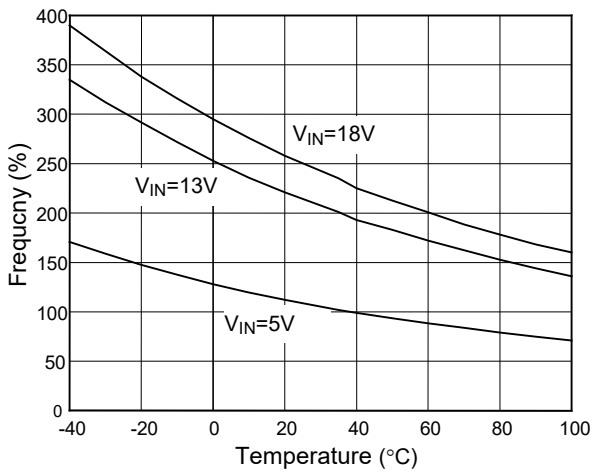

Fig. 3 Frequency vs. Temperature

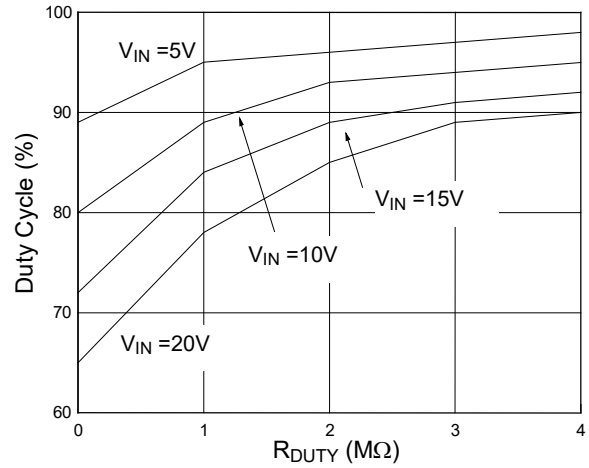

Fig. 4 Duty Cycle vs. R_{DUTY}

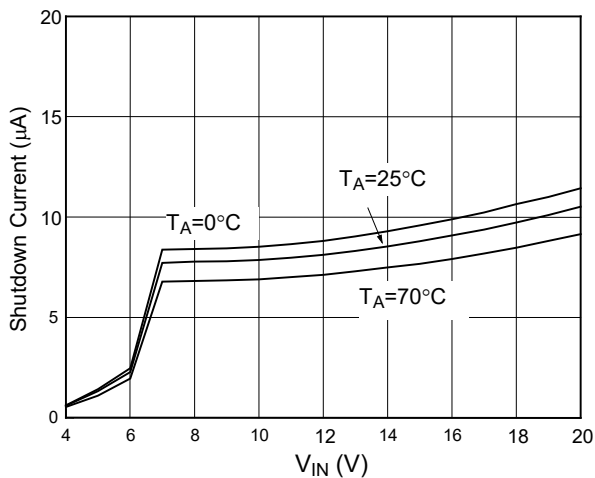

Fig. 5 Shutdown vs. V_{IN}

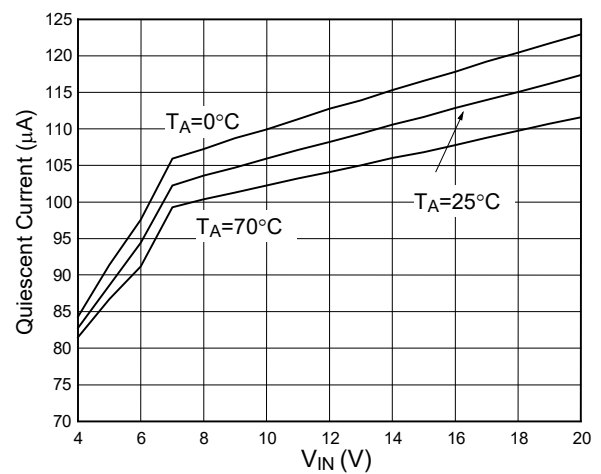
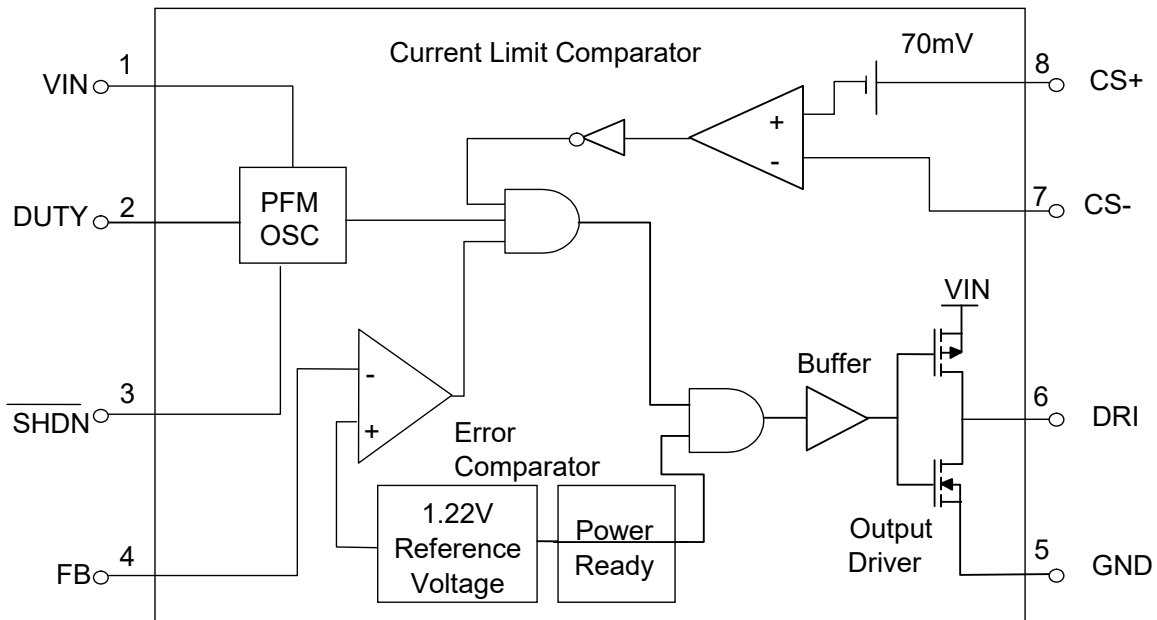

Fig. 6 Quiescent Current vs. V_{IN}

■ BLOCK DIAGRAM

■ PIN DESCRIPTIONS

- PIN 1: VIN - Input supply voltage, ranged from 4V to 18V is recommended.
- PIN 2: DUTY - Duty cycle adjustment pin. To be tied to the VIN pin directly or through a resistor R_{DUTY} to adjust oscillator duty cycle. R_{DUTY} must be over $1M\Omega$ if $V_{IN}=18V$. See TYPICAL PERFORMANCE CHARACTERISTICS.
- PIN 3: \overline{SHDN} - Logical input to shutdown the chip:
 $V_{\overline{SHDN}} = \text{High}$ for normal operation.
 $V_{\overline{SHDN}} = \text{Low}$ for shutdown.
 This pin should not be floating or be forced to over 15V. In shutdown mode DRI pins is at high level.
- PIN 4: FB - Feedback comparator input, to compare the feedback voltage with the internal reference

voltage. Connecting a resistor R_1 to converter output node and a resistor R_2 to ground yields the output voltage:

$$V_{OUT}=1.22 \times (R_1+R_2)/ R_2$$

- PIN 5: GND - Power ground.
- PIN 6: DRI - Push-pull driver output to drive an external P-channel MOSFET or PNP transistor. When driving a PNP bipolar transistor, a base resistor and a capacitor to the base of PNP are recommended.
- PIN 7: CS- - Current sense comparator inverting input. This pin voltage should go over 2V but not to exceed V_{IN} voltage.
- PIN 8: CS+ - Current sense comparator non-inverting input. This pin voltage should go over 2V but not to exceed V_{IN} voltage.

APPLICATION INFORMATION

Short Circuit Protection Design

- As we know, Short Circuit Protection (abbreviated as SCP) does not always exist in the DC-DC converter circuit. The fact is usually the DC-DC converter provides the circuits attached to VOUT with low power or low voltage. Sometimes it has less concern about safety. And its probability of short-circuit is quite low. That gives users reasons to ignore the use of SCP circuit. However, we would still like to point out the importance of the protection. With SCP, the system will be well protected in any situation. Two SCP circuits are introduced as follows for your reference.
- Design1: shown as Fig. 7.
Method: Add a fast fuse to VOUT.

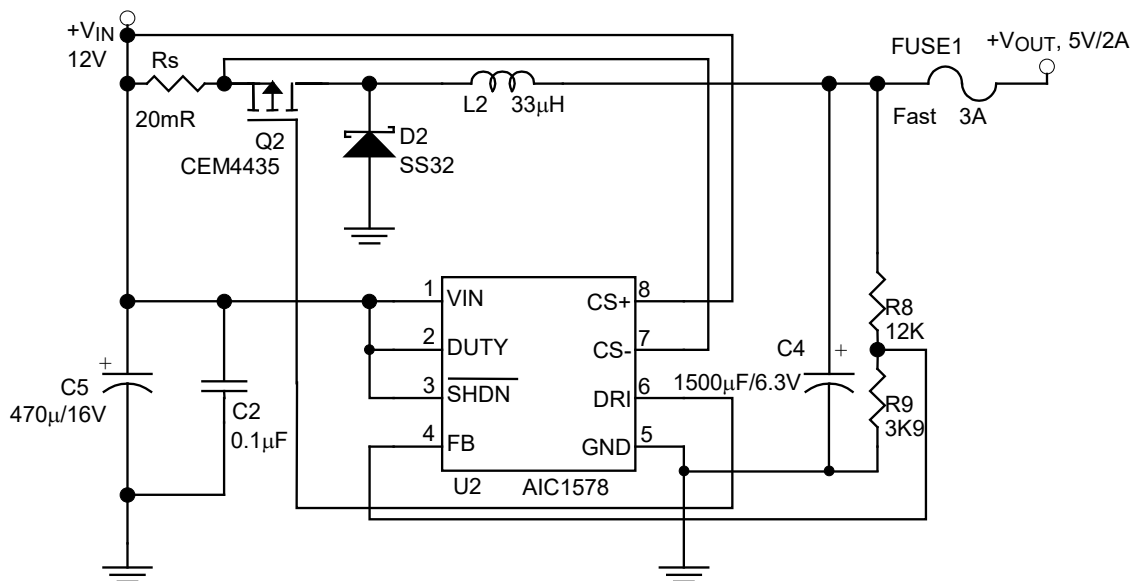

Fig 7. Add a Fast Fuse Solution

Fuse select guide: Fuses, which can take the start up current, and break down fast on unexpected current.

Note: Replacement of fuse is needed after short circuit.

- Design 2: shown as Fig. 8.

Method: Add a SCP circuit

Note:

- The time constant, which is directly related to R1 and C1, has a serious effect on the circuit.
- Circuit can be recovered by removing the short circuit event from the system.
- The condition for applying this design is $V_{OUT} \geq 3V$.

■ APPLICATION INFORMATION (Continued)

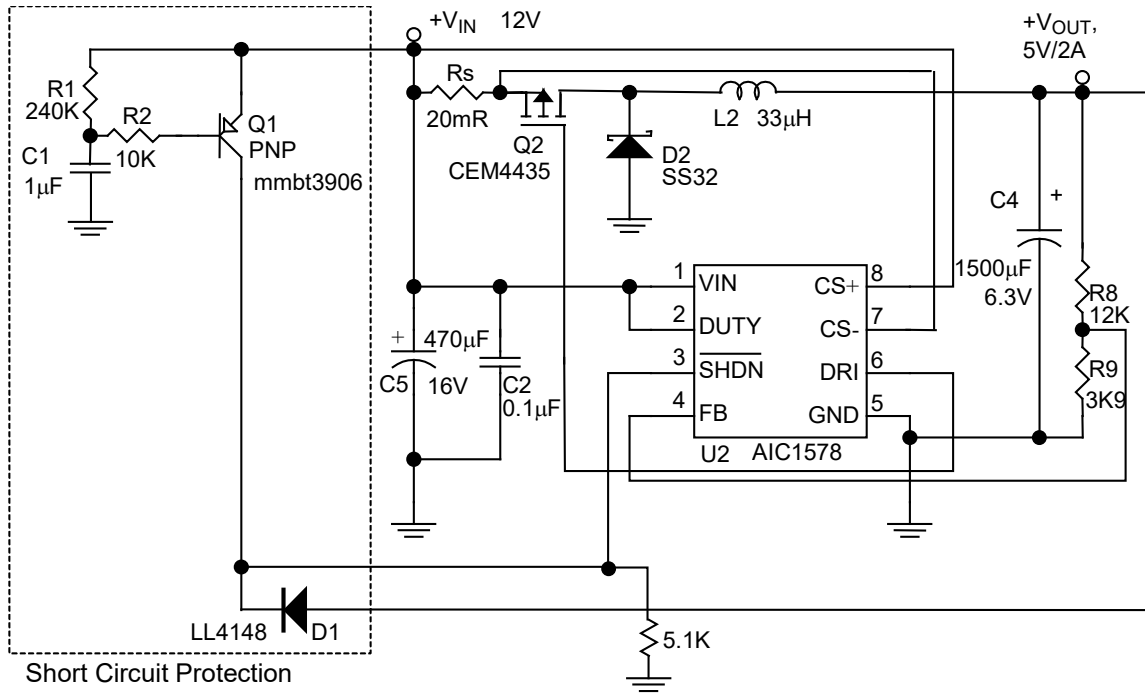
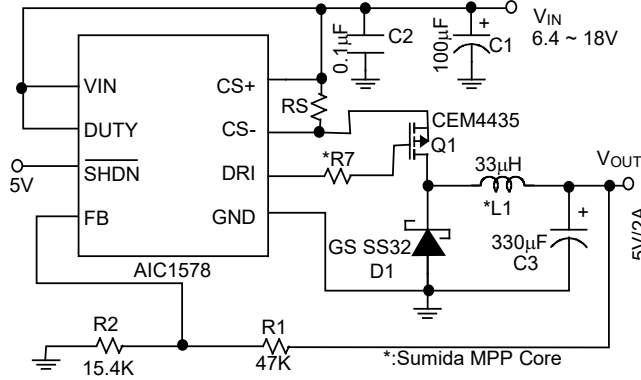

Fig 8. Add A Short Circuit Protection Circuit Solution

APPLICATION EXAMPLES



$V_{IN} > 15V, R7 = 15\Omega$
 $V_{IN} \leq 15V, R7 = 0\Omega$

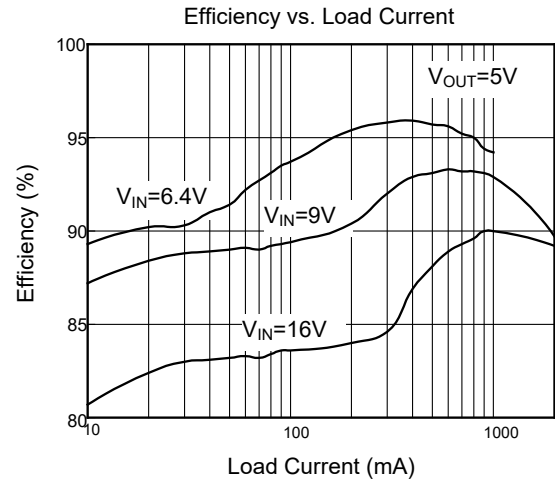
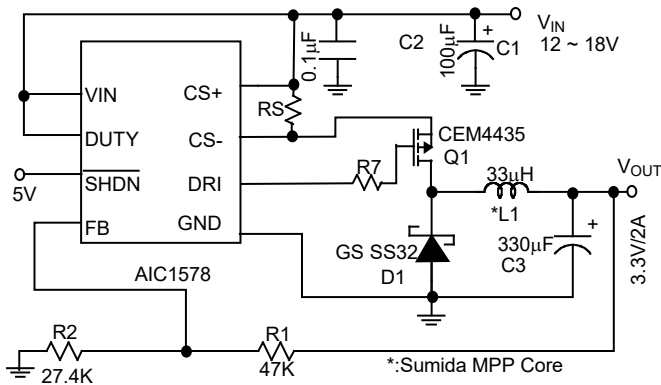

Fig. 9 5V Step-Down Converter



$V_{IN} > 15V, R7 = 15\Omega$
 $V_{IN} \leq 15V, R7 = 0\Omega$

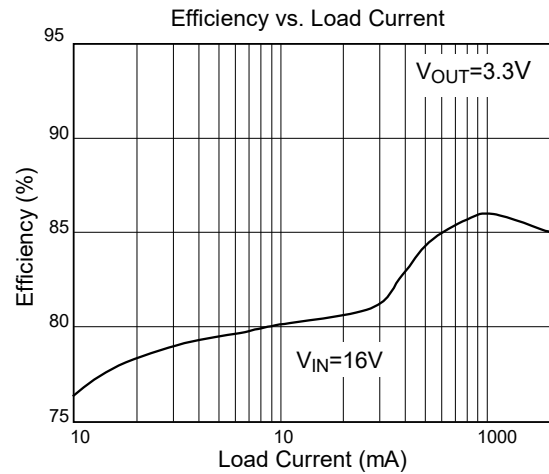
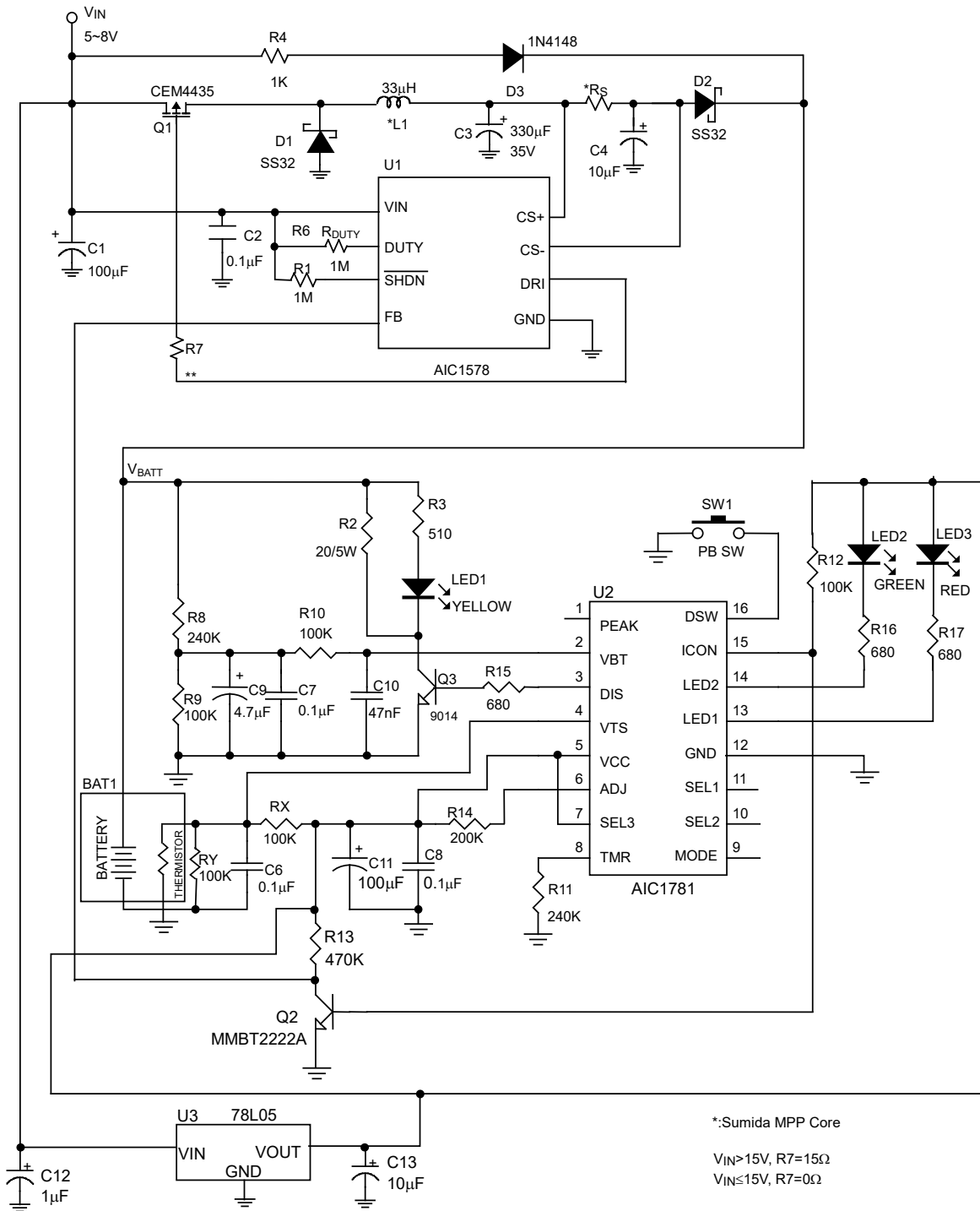

Fig. 10 3.3V Step-Down Converter

APPLICATION EXAMPLES (Continued)

NOTE: $R_s = 0.1\Omega$, charge current = $0.5A \pm 10\%$, $V_{IN} > V_{BATT} + 3.5V$
 $R_s = 0.05\Omega$, charge current = $1A \pm 10\%$, $V_{IN} > V_{BATT} + 4V$
 $R_s = 0.033\Omega$, charge current = $1.5A \pm 10\%$, $V_{IN} > V_{BATT} + 4.5V$
 Efficiency > 90%, measured at CS- node
 3~5 NiMH/NiCd Cells

Fig. 11 Battery Charge Circuit with High-Side Current Sensing Constant Current Source

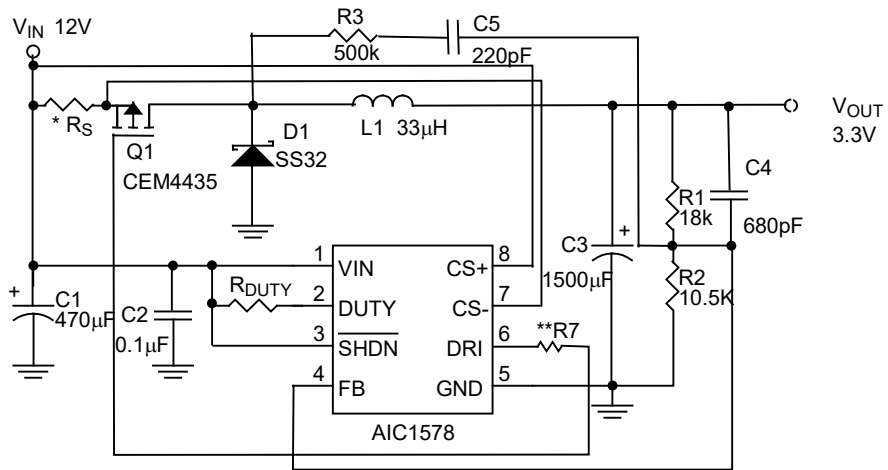
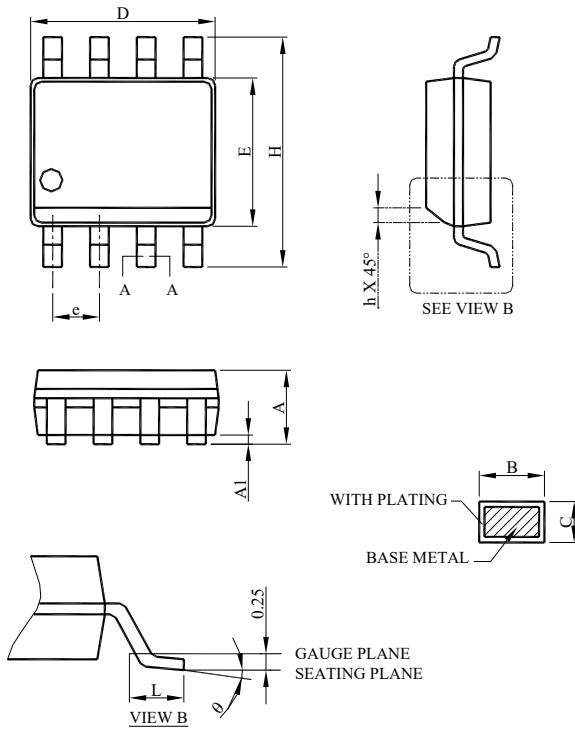

Fig. 12 Step-Down Converter

■ PHYSICAL DIMENSIONS (unit: mm)

● SOP-8



SYMBOL	SOP-8	
	MILLIMETERS	
	MIN.	MAX.
A	1.35	1.75
A1	0.10	0.25
B	0.33	0.51
C	0.19	0.25
D	4.80	5.00
E	3.80	4.00
e	1.27 BSC	
H	5.80	6.20
h	0.25	0.50
L	0.40	1.27
θ	0°	8°

- Note: 1. Refer to JEDEC MS-012AA.
 2. Dimension "D" does not include mold flash, protrusions or gate burrs. Mold flash, protrusion or gate burrs shall not exceed 6 mil per side .
 3. Dimension "E" does not include inter-lead flash or protrusions.
 4. Controlling dimension is millimeter, converted inch dimensions are not necessarily exact.

● DIP-8

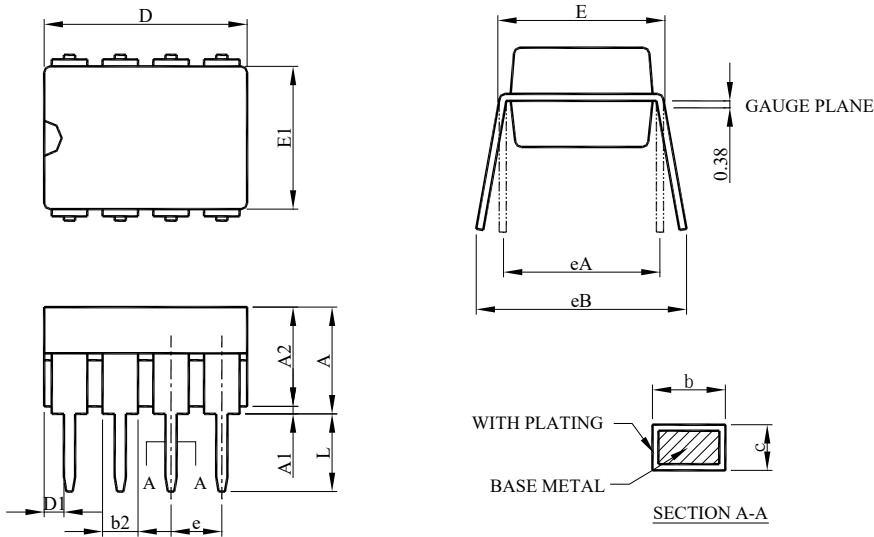

SYMBOL	DIP-8	
	MILLIMETERS	
	MIN.	MAX.
A		5.33
A1	0.38	
A2	2.92	4.95
b	0.36	0.56
b2	1.14	1.78
c	0.20	0.35
D	9.01	10.16
D1	0.13	
E	7.62	8.26
E1	6.10	7.11
e	2.54 BSC	
eA	7.62 BSC	
eB		10.92
L	2.92	3.81

- Note: 1. Refer to JEDEC MS-001BA
 2. Dimension "D" does not include mold flash, protrusions or gate burrs. Mold flash, protrusion or gate burrs shall not exceed 10 mil per side .
 3. Dimension "D1" and "E1" do not include inter-lead flash or protrusions.
 4. Controlling dimension is millimeter, converted inch dimensions are not necessarily exact.

Note:

Information provided by AIC is believed to be accurate and reliable. However, we cannot assume responsibility for use of any circuitry other than circuitry entirely embodied in an AIC product; nor for any infringement of patents or other rights of third parties that may result from its use. We reserve the right to change the circuitry and specifications without notice.

Life Support Policy: AIC does not authorize any AIC product for use in life support devices and/or systems. Life support devices or systems are devices or systems which, (i) are intended for surgical implant into the body or (ii) support or sustain life, and whose failure to perform, when properly used in accordance with instructions for use provided in the labeling, can be reasonably expected to result in a significant injury to the user.